



DUAL POWER OPERATIONAL AMPLIFIERS

- OUTPUT CURRENT TO 1 A
- OPERATES AT LOW VOLTAGES
- SINGLE OR SPLIT SUPPLY
- LARGE COMMON-MODE AND DIFFERENTIAL MODE RANGE
- GROUND COMPATIBLE INPUTS
- LOW SATURATION VOLTAGE
- THERMAL SHUTDOWN

DESCRIPTION

The L272 is a monolithic integrated circuits in Powerdip, Minidip and SO packages intended for use as power operational amplifiers in a wide range of applications including servo amplifiers and power supplies, compacts disc, VCR, etc.

The high gain and high output power capability provide superior performance whatever an operational amplifier/power booster combination is required.

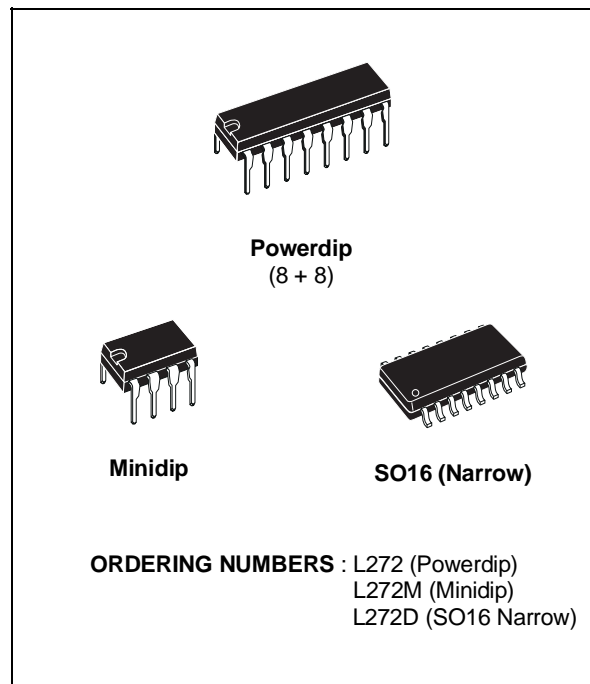

PIN CONNECTIONS (top view)

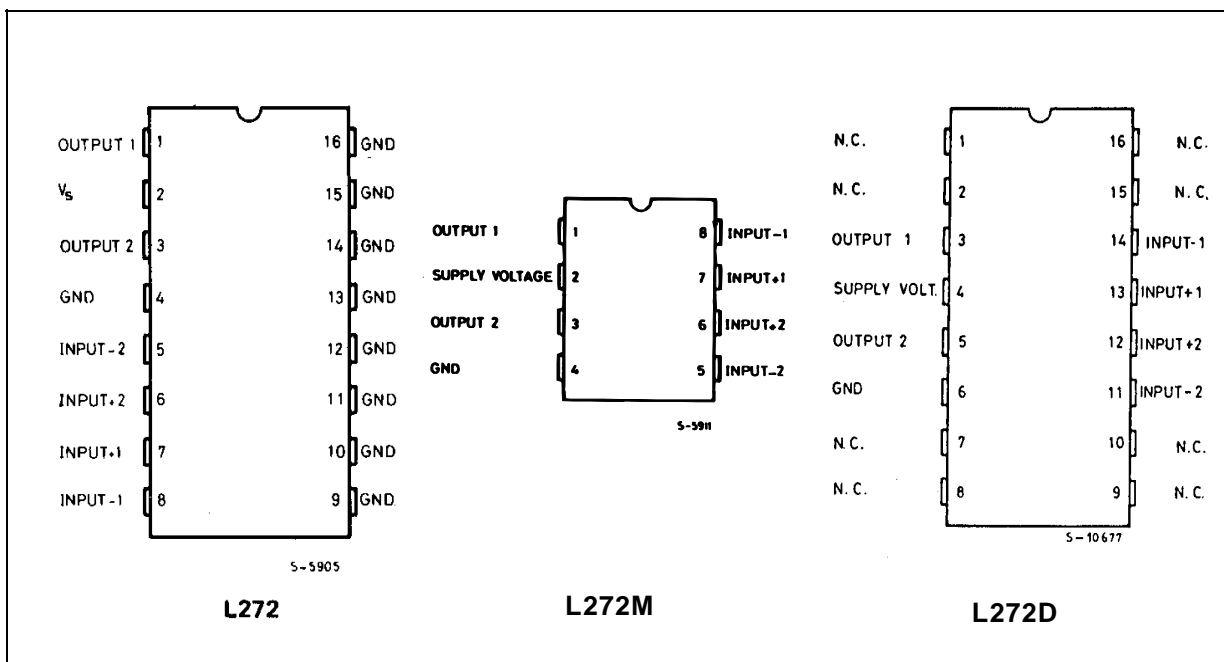

BLOCK DIAGRAMS

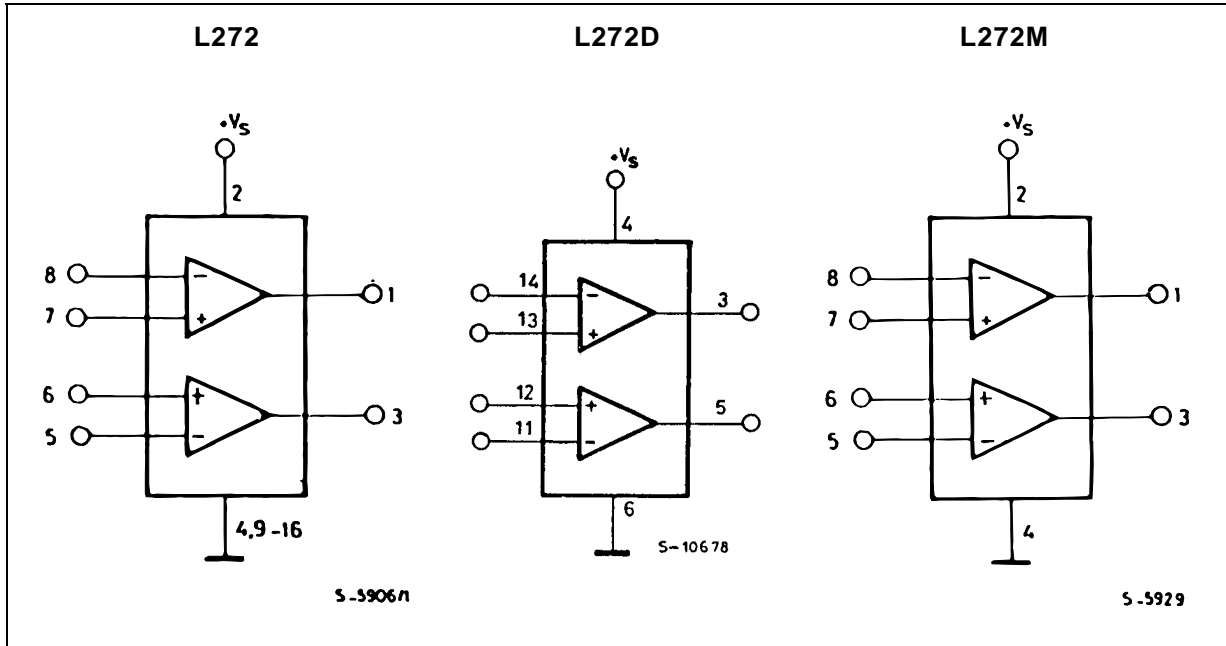

SCHEMATIC DIAGRAM (one only)

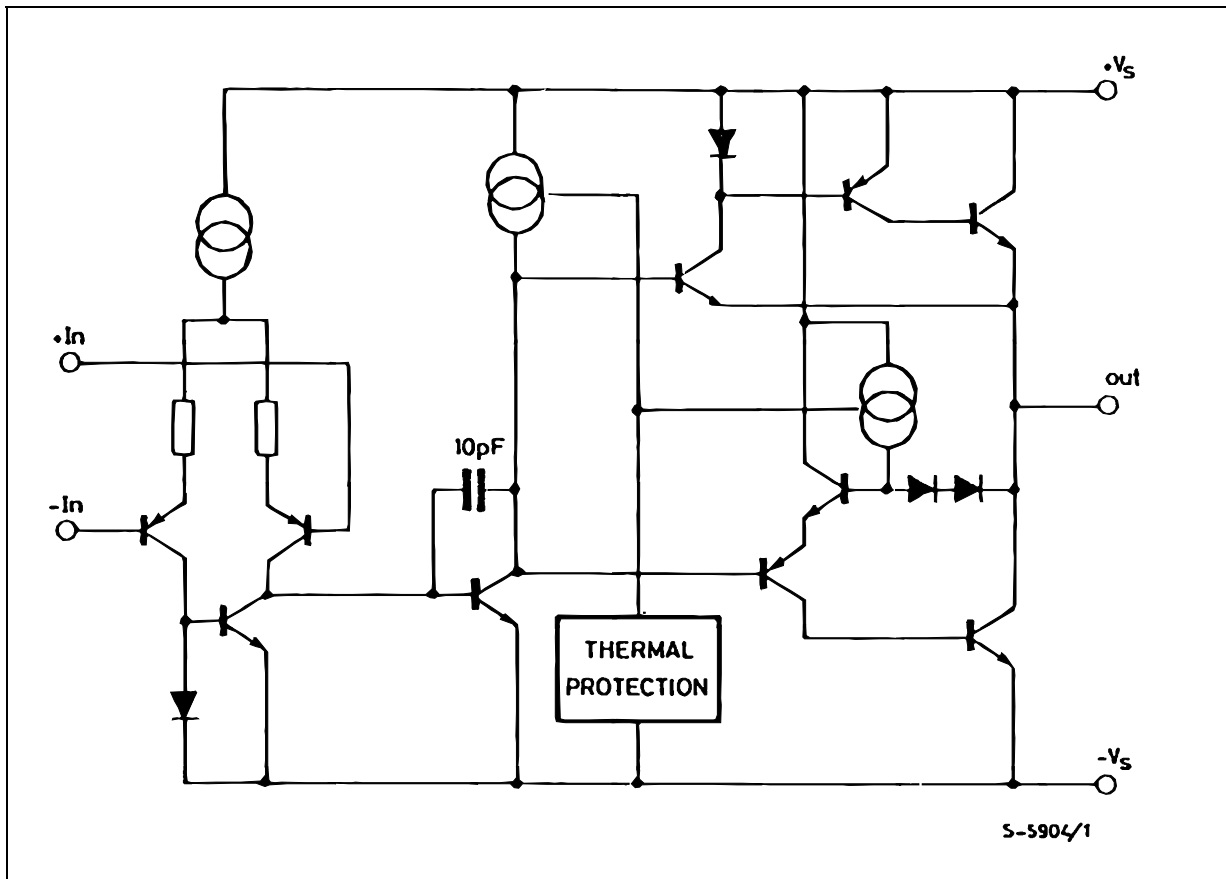

ABSOLUTE MAXIMUM RATINGS

Symbol	Parameter	Value	Unit
V_s	Supply Voltage	28	V
V_i	Input Voltage	V_s	
V_i	Differential Input Voltage	$\pm V_s$	
I_o	DC Output Current	1	A
I_p	Peak Output Current (non repetitive)	1.5	A
P_{tot}	Power Dissipation at: $T_{amb} = 80^\circ\text{C}$ (L272), $T_{amb} = 50^\circ\text{C}$ (L272M), $T_{case} = 90^\circ\text{C}$ (L272D) $T_{case} = 75^\circ\text{C}$ (L272)	1.2 5	W W
T_{op}	Operating Temperature Range (L272D)	- 40 to 85	$^\circ\text{C}$
T_{stg}, T_j	Storage and Junction Temperature	- 40 to 150	$^\circ\text{C}$

THERMAL DATA

Symbol	Parameter	Powerdip	SO16	Minidip	Unit
$R_{th\ j-case}$	Thermal Resistance Junction-pins Max.	15	-	* 70	$^\circ\text{C}/\text{W}$
$R_{th\ j-amb}$	Thermal Resistance Junction-ambient Max.	70	-	100	$^\circ\text{C}/\text{W}$
$R_{th\ j-alumina}$	Thermal Resistance Junction-alumina Max.	-	** 50	-	$^\circ\text{C}/\text{W}$

* Thermal resistance junction-pin 4

** Thermal resistance junctions-pins with the chip soldered on the middle of an alumina supporting substrate measuring 15x 20mm; 0.65mm thickness and infinite heatsink.

ELECTRICAL CHARACTERISTICS ($V_s = 24\text{V}$, $T_{amb} = 25^\circ\text{C}$ unless otherwise specified)

Symbol	Parameter	Test Conditions	Min.	Typ.	Max.	Unit
V_s	Supply Voltage		4		28	V
I_s	Quiescent Drain Current	$V_o = \frac{V_s}{2}$ $V_s = 24\text{V}$ $V_s = 12\text{V}$		8 7.5	12 11	mA mA
I_b	Input Bias Current			0.3	2.5	μA
V_{os}	Input Offset Voltage			15	60	mV
I_{os}	Input Offset Current			50	250	nA
SR	Slew Rate			1		V/ μs
B	Gain-bandwidth Product			350		kHz
R_i	Input Resistance		500			k Ω
G_v	O. L. Voltage Gain	$f = 100\text{Hz}$ $f = 1\text{kHz}$	60	70 50		dB dB
e_N	Input Noise Voltage	B = 20kHz		10		μV
I_N	Input Noise Current	B = 20kHz		200		pA
CRR	Common Mode Rejection	$f = 1\text{kHz}$	60	75		dB
SVR	Supply Voltage Rejection	$f = 100\text{Hz}$, $R_G = 10\text{k}\Omega$, $V_R = 0.5\text{V}$ $V_s = 24\text{V}$ $V_s = \pm 12\text{V}$ $V_s = \pm 6\text{V}$	54	70 62 56		dB
V_o	Output Voltage Swing	$I_p = 0.1\text{A}$ $I_p = 0.5\text{A}$	21	23 22.5		V V
C_s	Channel Separation	$f = 1\text{kHz}$; $R_L = 10\Omega$, $G_v = 30\text{dB}$ $V_s = 24\text{V}$ $V_s = \pm 6\text{V}$		60 60		dB
d	Distortion	$f = 1\text{kHz}$, $G_v = 3\text{dB}$, $V_s = 24\text{V}$, $R_L = \infty$		0.5		%
T_{sd}	Thermal Shutdown Junction Temperature			145		$^\circ\text{C}$

Figure 1 : Quiescent Current versus Supply Voltage

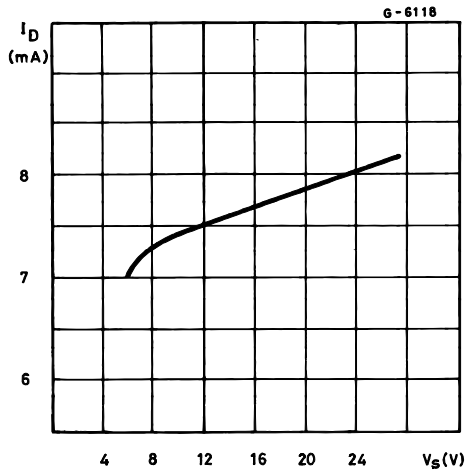

Figure 2 : Quiescent Drain Current versus Temperature

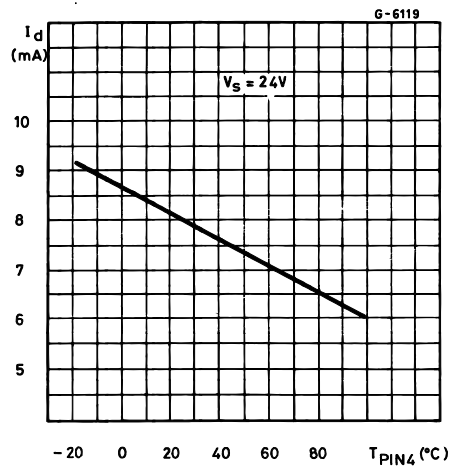

Figure 3 : Open Loop Voltage Gain

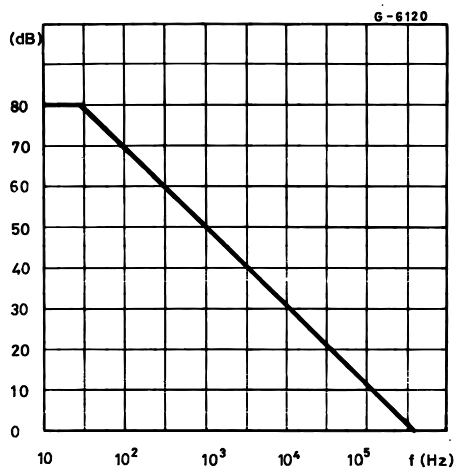

Figure 4 : Output Voltage Swing versus Load Current

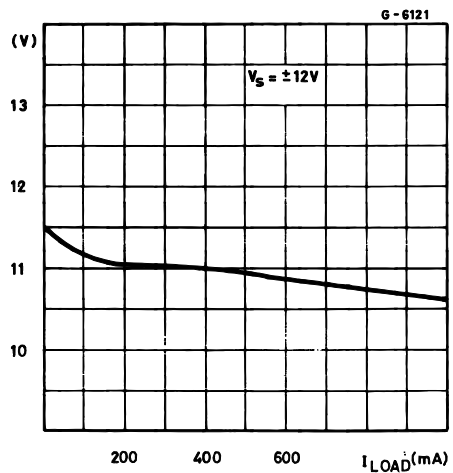

Figure 5 : Output Voltage Swing versus Load Current

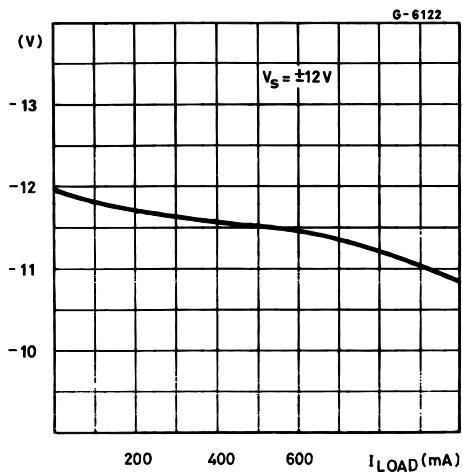

Figure 6 : Supply Voltage Rejection versus Frequency

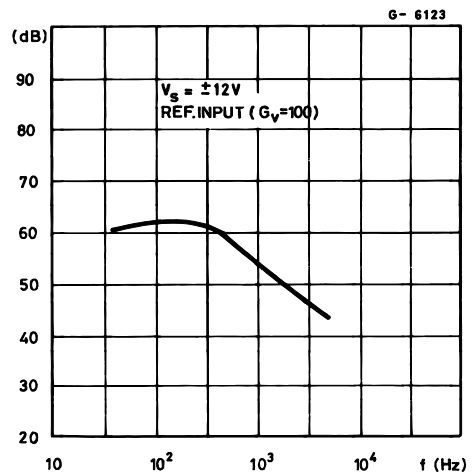

Figure 7 : Channel Separation versus Frequency

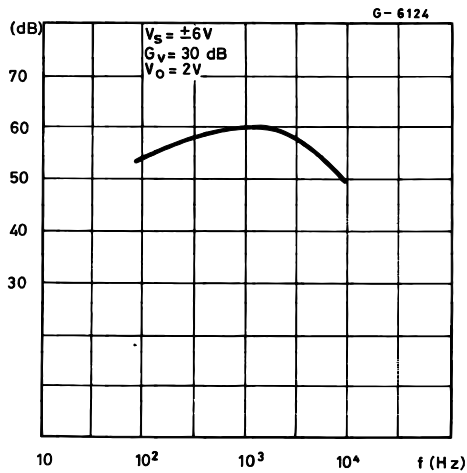
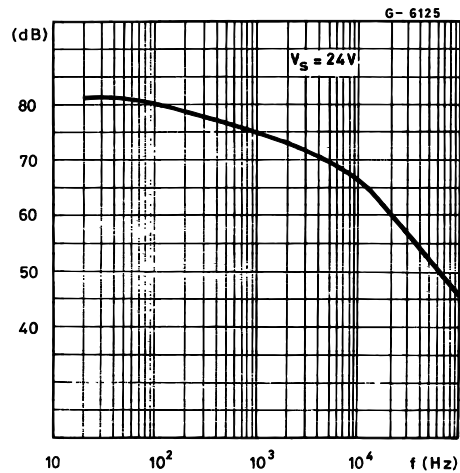

Figure 8 : Common Mode Rejection versus Frequency



APPLICATION SUGGESTION

NOTE

In order to avoid possible instability occurring into final stage the usual suggestions for the linear power stages are useful, as for instance :

- layout accuracy ;
- a 100nF capacitor connected between supply pins and ground ;
- boucherot cell (0.1 to 0.2 μ F + 1 Ω series) between

Figure 9 : Bidirectional DC Motor Control with μ P Compatible Inputs

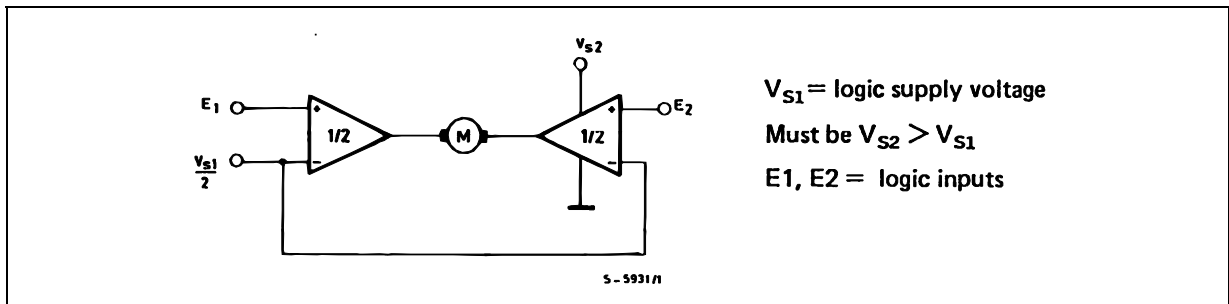

Figure 10 : Servocontrol for Compact-disc

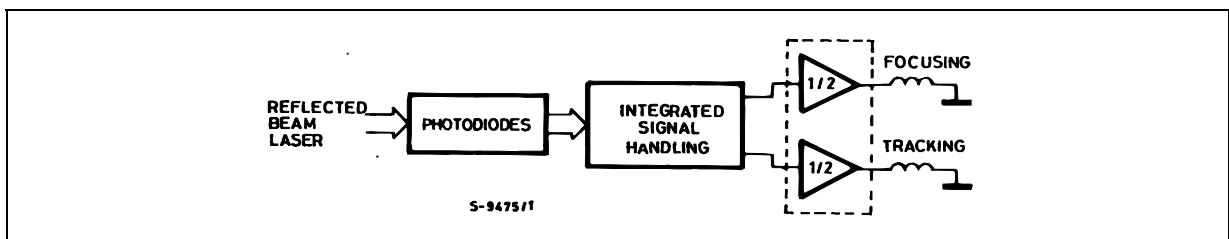

Figure 11 : Capstan Motor Control in Video Recorders

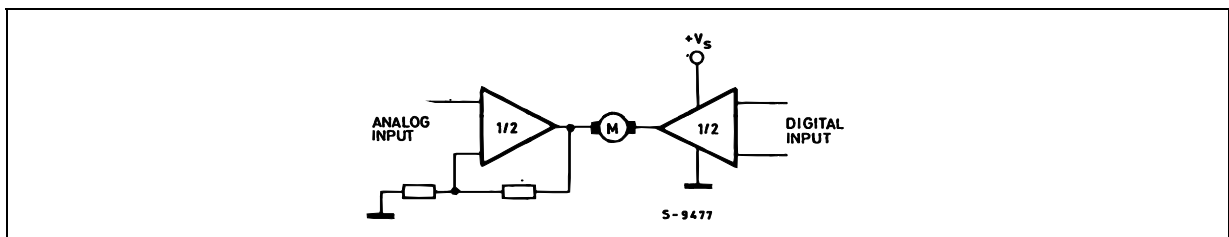
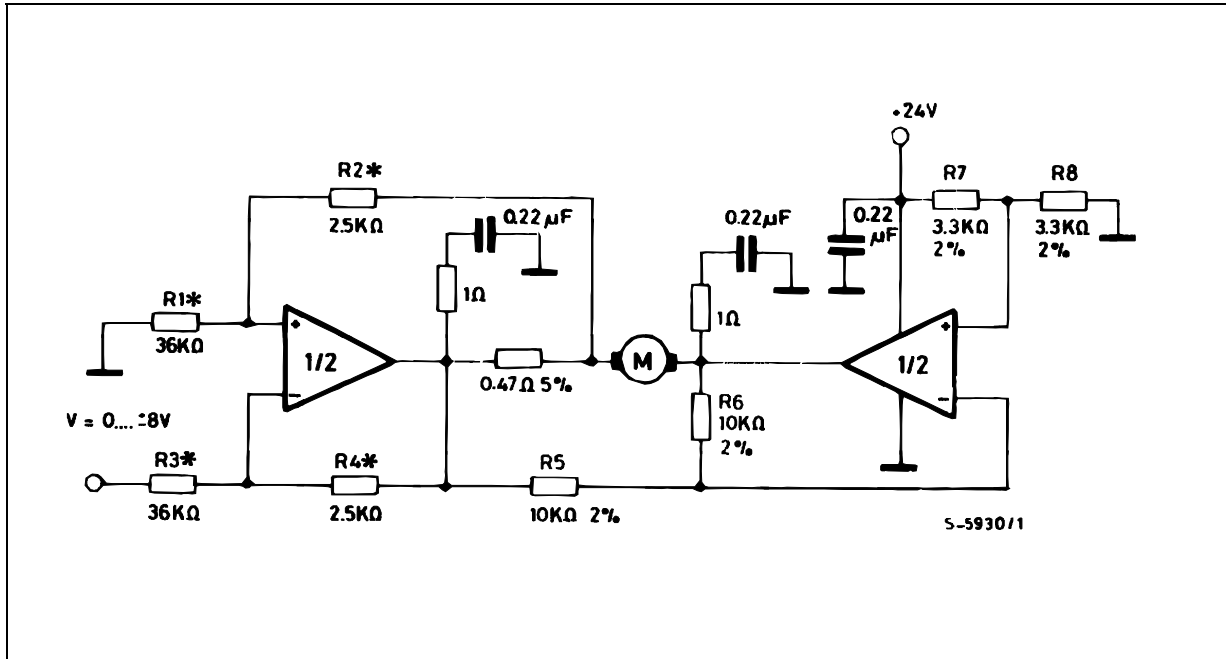

Figure 12 : Motor Current Control Circuit.



Note : The input voltage level is compatible with L291 (5-BIT D/A converter).

Figure 13 : Bidirectional Speed Control of DC Motors.

For circuit stability ensure that $R_x > \frac{2R_3 \cdot R_1}{R_M}$ where R_M = internal resistance of motor.

The voltage available at the terminals of the motor is $V_M = 2 \left(V_i \cdot \frac{V_s}{2} \right) + |R_o| \cdot I_M$ where $|R_o| = \frac{2R \cdot R_1}{R_x}$ and I_M is the motor current.

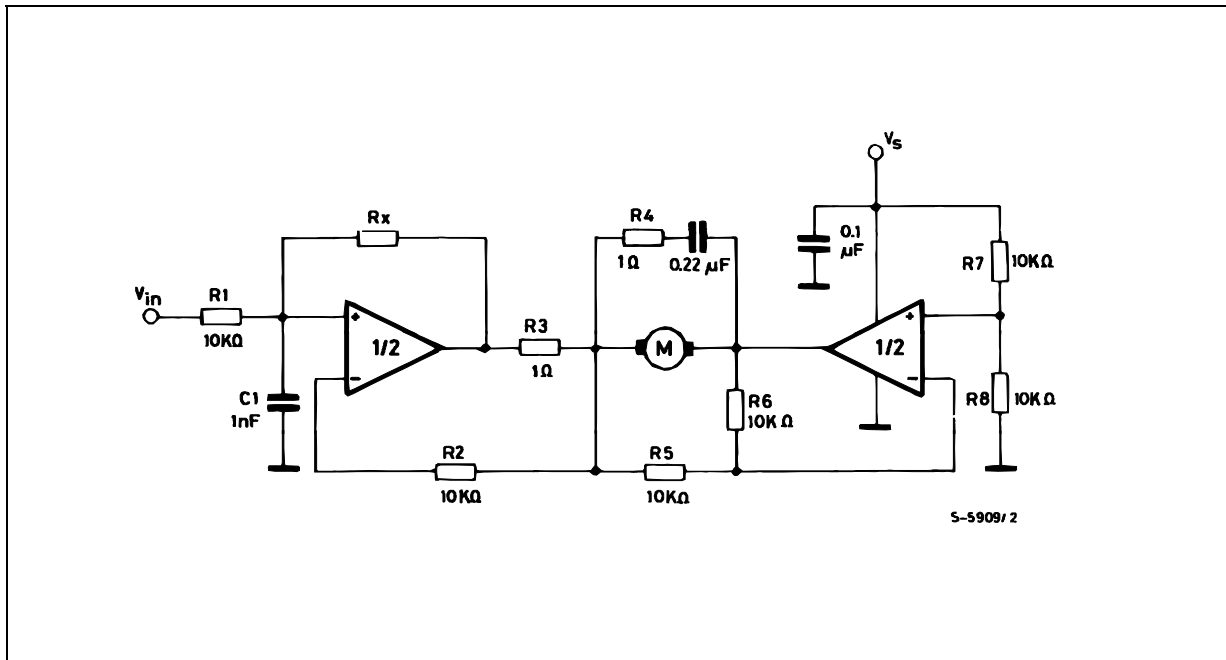

DIM.	mm			inch		
	MIN.	TYP.	MAX.	MIN.	TYP.	MAX.
a1	0.51			0.020		
B	0.85		1.40	0.033		0.055
b		0.50			0.020	
b1	0.38		0.50	0.015		0.020
D			20.0			0.787
E		8.80			0.346	
e		2.54			0.100	
e3		17.78			0.700	
F			7.10			0.280
I			5.10			0.201
L		3.30			0.130	
Z			1.27			0.050

OUTLINE AND MECHANICAL DATA

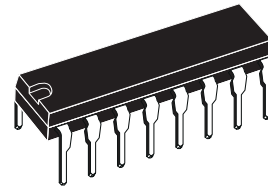

Powerdip 16

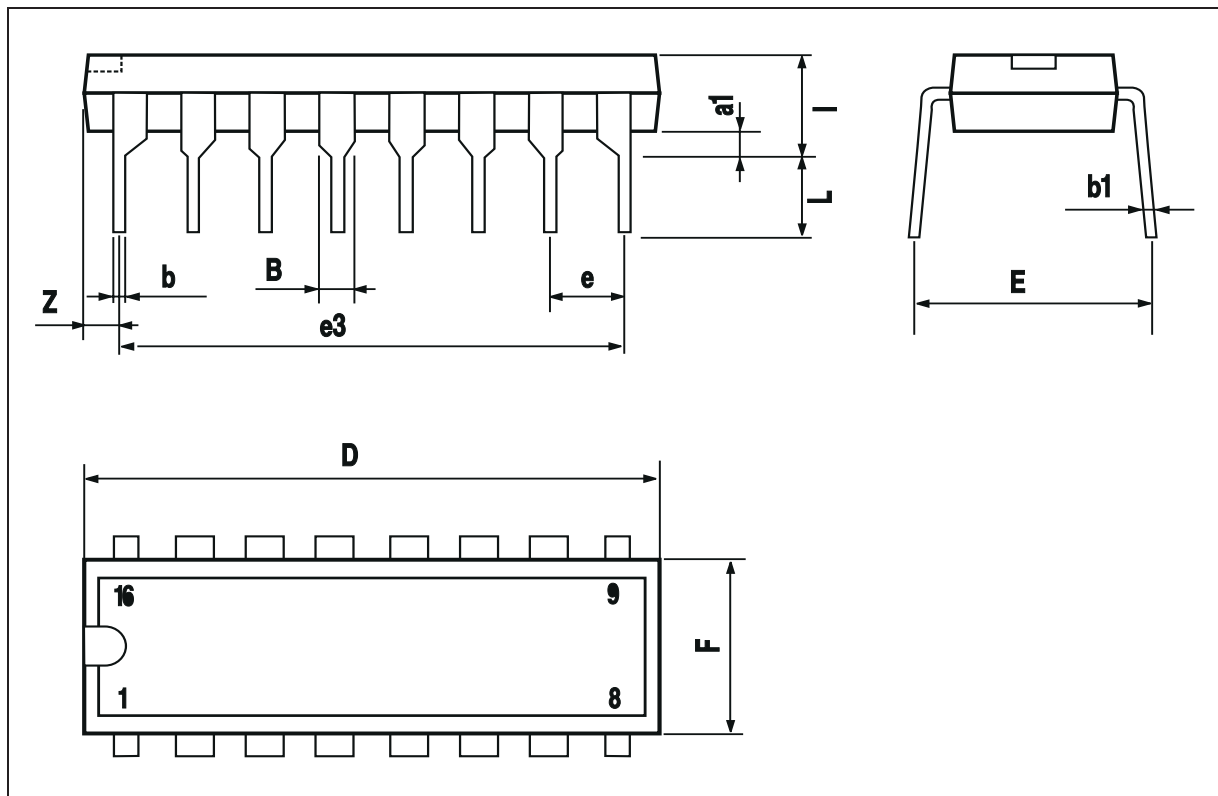

DIM.	mm			inch		
	MIN.	TYP.	MAX.	MIN.	TYP.	MAX.
A		3.32			0.131	
a1	0.51			0.020		
B	1.15		1.65	0.045		0.065
b	0.356		0.55	0.014		0.022
b1	0.204		0.304	0.008		0.012
D			10.92			0.430
E	7.95		9.75	0.313		0.384
e		2.54			0.100	
e3		7.62			0.300	
e4		7.62			0.300	
F			6.6			0.260
I			5.08			0.200
L	3.18		3.81	0.125		0.150
Z			1.52			0.060

OUTLINE AND MECHANICAL DATA

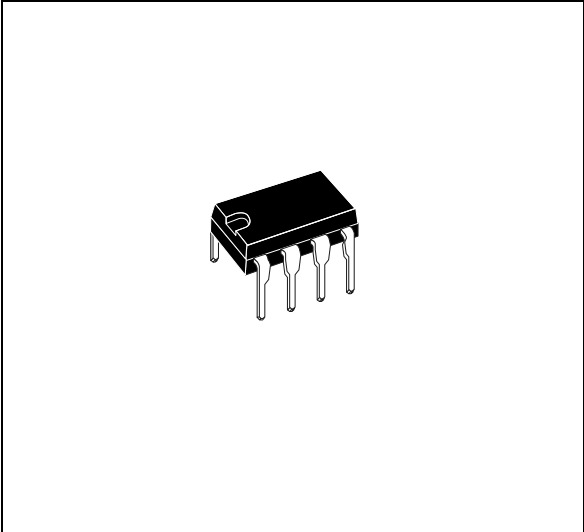

Minidip

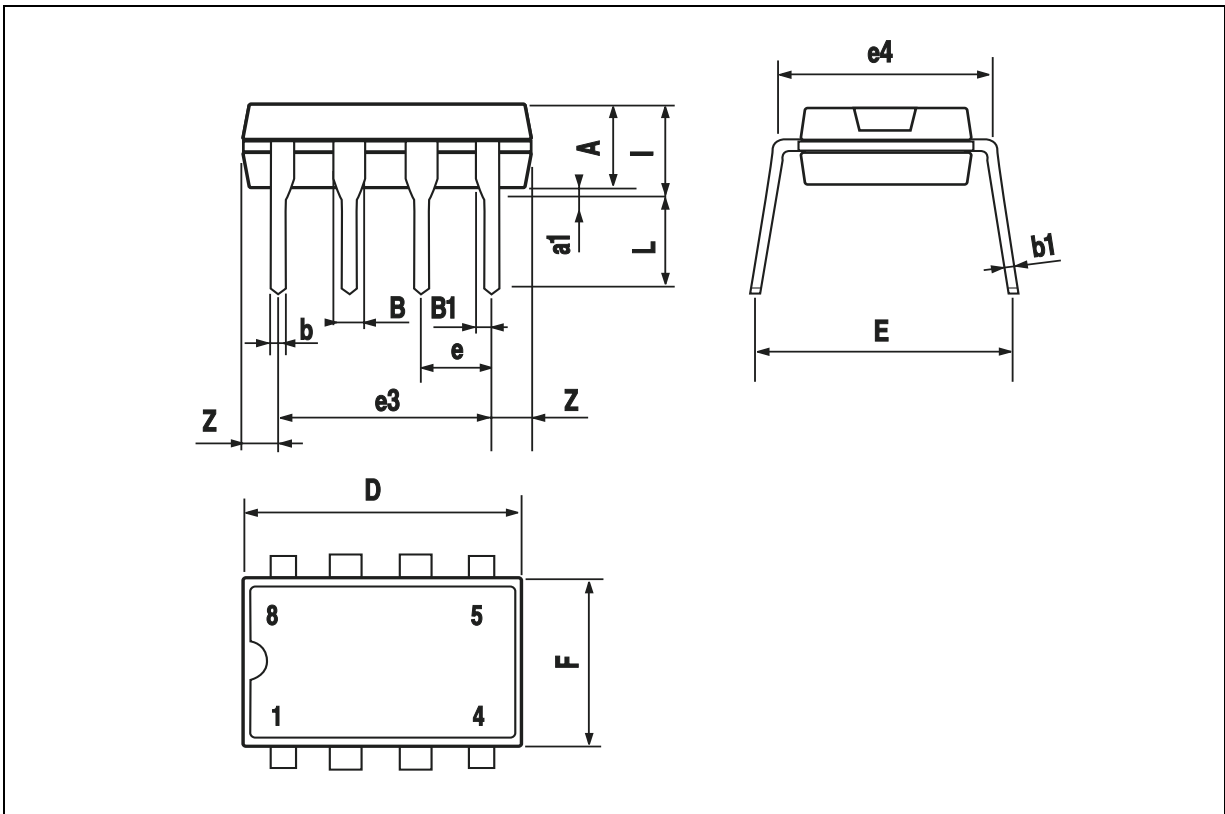

DIM.	mm			inch		
	MIN.	TYP.	MAX.	MIN.	TYP.	MAX.
A			1.75			0.069
a1	0.1		0.25	0.004		0.009
a2			1.6			0.063
b	0.35		0.46	0.014		0.018
b1	0.19		0.25	0.007		0.010
C		0.5			0.020	
c1	45° (typ.)					
D (1)	9.8		10	0.386		0.394
E	5.8		6.2	0.228		0.244
e		1.27			0.050	
e3		8.89			0.350	
F (1)	3.8		4	0.150		0.157
G	4.6		5.3	0.181		0.209
L	0.4		1.27	0.016		0.050
M			0.62			0.024
S	8° (max.)					

OUTLINE AND MECHANICAL DATA

Weight: 0.20gr

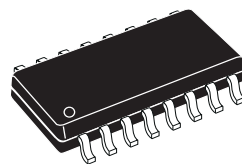

SO16 Narrow

(1) D and F do not include mold flash or protrusions. Mold flash or protrusions shall not exceed 0.15mm (.006inch).

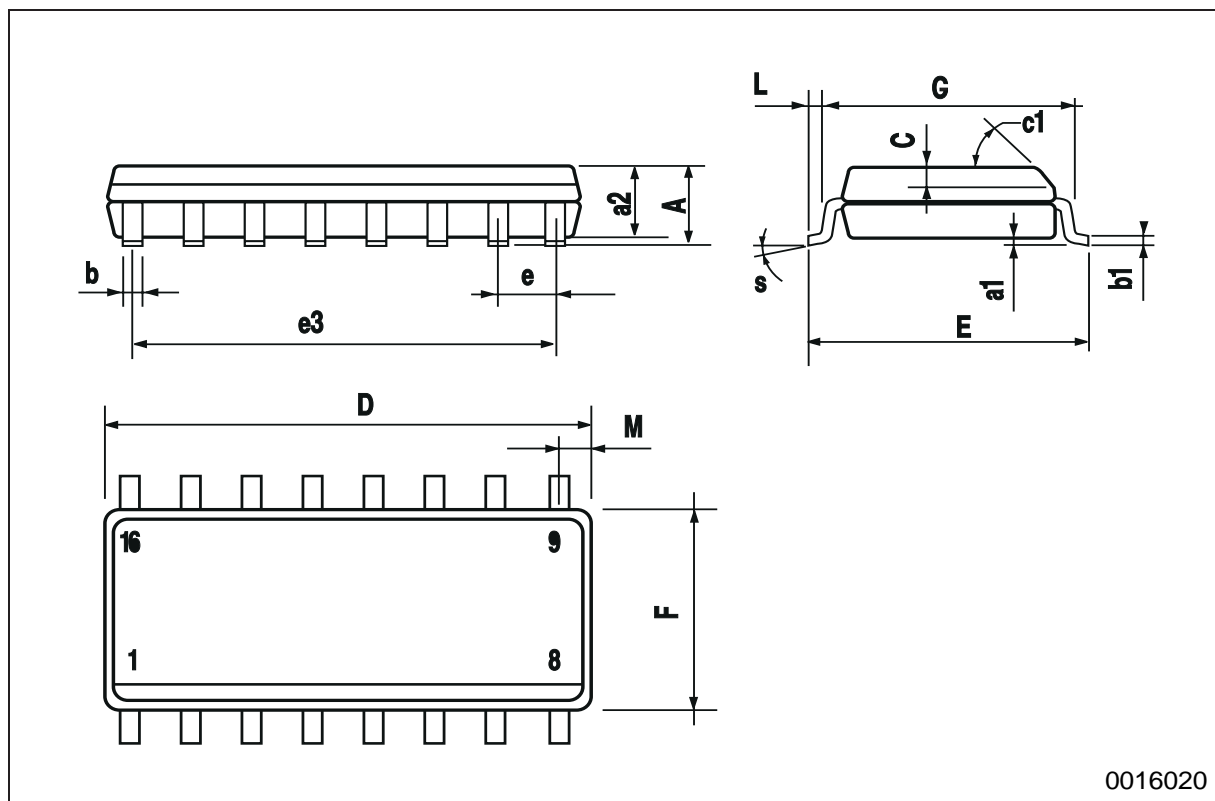

Information furnished is believed to be accurate and reliable. However, STMicroelectronics assumes no responsibility for the consequences of use of such information nor for any infringement of patents or other rights of third parties which may result from its use. No license is granted by implication or otherwise under any patent or patent rights of STMicroelectronics. Specification mentioned in this publication are subject to change without notice. This publication supersedes and replaces all information previously supplied. STMicroelectronics products are not authorized for use as critical components in life support devices or systems without express written approval of STMicroelectronics.

The ST logo is a registered trademark of STMicroelectronics
© 2003 STMicroelectronics – Printed in Italy – All Rights Reserved
STMicroelectronics GROUP OF COMPANIES

Australia - Brazil - Canada - China - Finland - France - Germany - Hong Kong - India - Israel - Italy - Japan - Malaysia - Malta - Morocco -
Singapore - Spain - Sweden - Switzerland - United Kingdom - United States.
<http://www.st.com>